



A Microcontroller-based RFID Record Tracker for COVID-19 Pandemic

Su Shen Lim^{1,*}, Adibah Zairul Nisha¹, Fatin Ayuni MD Khalid¹,
Jin Xiu Chua¹ and Yuan Wen Hau^{1,2}

¹Department of Biomedical Engineering and Health Sciences, Faculty of Electrical Engineering, Universiti Teknologi Malaysia, 81310 Johor Bahru, Johor, Malaysia.

²IJN-UTM Cardiovascular Engineering Centre, Institute of Human Centered Engineering, Universiti Teknologi Malaysia, 81310 UTM Johor Bahru, Johor, Malaysia.

* Corresponding Author limsushen@graduate.utm.my

Received 02 July 2023; Accepted 06 August 2023; Available online 06 August 2023
<https://doi.org/10.11113/humentech.v2n2.60>

Abstract:

Covid-19, also known as coronavirus disease 2019, is a highly contagious disease primarily transmitted through respiratory droplets. To mitigate the spread of the virus, the Malaysia government have implemented measures such as MySejahtera app for contact tracking purposes. The ‘Check-in’ feature is the core element in MySejahtera app where users will scan a QR code prior to entering a premise. However, it has some drawbacks in which a phone with internet connectivity and working camera are needed to scan the QR code. To overcome the limitations and ease the burden on the public, this paper proposes a RFID record tracker based on Atmel ATmega328P and NodeMCU ESP-12E technology as a complementary function to the ‘Check-in’ feature offered by MySejahtera. It has a RFID reader and built-in temperature sensor. It is ideally visualized to be sharing the same database with MySejahtera. This solution can be connected to the WiFi of the premise, thus the public just have to bring their Malaysian IC or relative RFID tag along with them. Once scanned, the system will crosscheck with the connected database to check their vaccination status and determine whether to grant access for them to enter the premise. At the same time, their record will be logged into associated database of the premise as well. All in all, this solution is designed in hopes to reduce the burden on public while easing the process of contact tracing.

Keywords: Covid-19; MySejahtera; Contact tracing; Microcontroller; RFID reader; Temperature sensor, Database

1. Introduction

Coronavirus disease 2019 (COVID-19) is a disease caused by a novel coronavirus currently known as severe acute respiratory syndrome coronavirus 2 (SARS-CoV-2; formerly called 2019-nCoV). It is a highly infectious disease. Coronavirus is most likely to be transmitted through respiratory droplets discharged into the air when an infected person coughs, sneezes, speaks, or breathes in close proximity to other individuals. Infection with coronavirus can also occur by skin-to-skin contact with an infected individual, followed by facial contact. Based on the latest statistics published by Ministry of Health and Department of Statistics Malaysia, there are a total of 4,600,736 cases with 35819 deaths reported in Malaysia as of June 2022 [1].

The drastic rise of COVID-19 cases has alarmed every city, urging the government to implement curfews, closing borders and restricting movements of citizens. As an initiative to combat this disease, effective ‘Tracing and Tracking’ of both infected patients and healthcare staffs has become a priority [2, 3]. High level technologies are incorporated into the process. With this regard, the Malaysian government has developed MySejahtera, a mobile application to aid in contact tracing operations. The application is equipped with reliable features such as latest statistics and health screening locations. The ‘Check-in’ feature is the core element of contact tracing through MySejahtera. Users are required to scan

a quick response (QR) code prior to entering a premise, and the system will record their previously visited locations in the past [4].

However, it has been identified to have a number of limitations in terms of efficiency and accessibility. To be able to use MySejahtera, the device would need to have Internet connectivity and power. It also requires a working camera to scan the QR code. In addition, QR codes can only be scanned when visible and in line of sight. The static nature of QR codes made it impossible to overwrite. Based on Sandakan Member of Parliament, Vivian Wong Shir Yee, MySejahtera app had clearly left out many members of society, especially senior citizens and B40 families who are either not tech-savvy or do not own a smartphone [5]. Therefore, she urged the Government to come up with an alternative that allows that segment of society to live in the new normal without owning a smartphone.

Thus, with the aforementioned issues, this solution has been proposed as an alternative for users to check-in into premises, without the need for a smartphone. Please note that the proposed solution is not a substitute of MySejahtera, but it is more like a complementary function to the ‘Check-in’ feature offered by the application. It allows users to check-in into premises just by scanning a radio frequency identification (RFID) card, for example Malaysia identity card to a programmed RFID reader. It is also ideally visualized to be sharing the same database with MySejahtera. The proposed solution utilizes the technology of RFID. A basic RFID system has three main elements, a tag, a reader and an antenna. An integrated chip would often be included in an RFID tag. Its purpose is to transmit data to the RFID reader. The data will then be translated into a more readable data format. This information will be recorded and collected in a database for analyzing purposes.

The RFID systems are supported by a high-level software architecture, enabling real-time capture and delivery of location-based data [6-8]. Each RFID tag has its own unique electronic product code (EPC) that enables the system to read long-range frequency and be overwritten. This allows users to have real-time access to a globally defined database, hence easing the ‘Tracing and Tracking’ process.

2. Methodology

2.1 Project design

This section discusses the project design of the proposed RFID record tracker which includes top level functional block diagrams, flowcharts and codes for the functional prototype.

2.1.1 System architecture

Figure 1 depicts the top-level functional block diagram of the proposed RFID record tracker. Arduino Uno R3 serves as a microcontroller and the brain of this study. Four (4) peripherals are connected to it as an input circuit. NodeMCU ESP-12E provides WiFi connectivity for the circuit while RC522 RFID reader reads the EPC and other relevant information from scanned tags, including name and vaccination status.

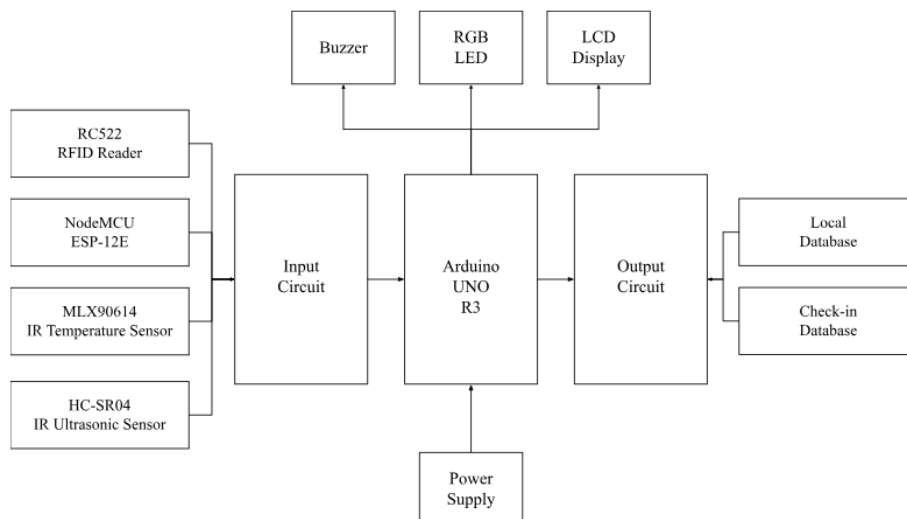

Figure 1 Top level functional block diagram

The MLX90614 infrared (IR) temperature sensor and HC-SR04 ultrasonic sensor work simultaneously to read users' body temperature within the range of 10 cm. buzzer, light emitting diode (LED) and liquid crystal display (LCD) display functions as output peripherals. These components will all operate differently depending on the users' status. The LCD display will print out users' status and access to the premise according to the information received from their tag. Both databases will record the information needed such as EPC, name, vaccination status and timestamp. Figure 2 shows the schematic diagram of the top-level system architecture of the proposed solution.

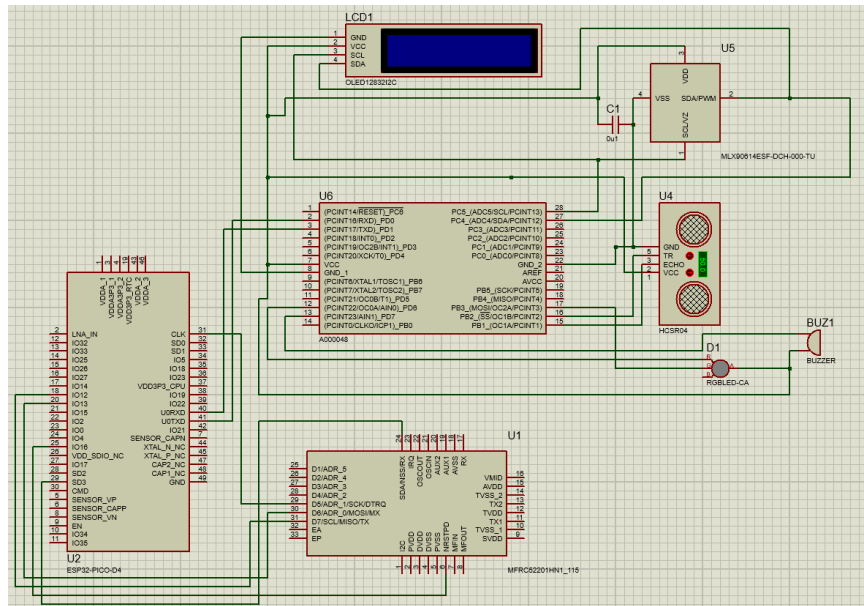

Figure 2 Top level architecture schematic diagram of RFID record tracker

2.2.1 System workflow

Figure 3 shows the system workflow from a user's perspective. Users would first need to scan their tags to gain access to the premise. Vaccination status associated with the tags will determine whether they are allowed to enter. After checking the vaccination status, the system will proceed to check users' body temperature. Incomplete vaccination status or high body temperature will trigger the system and deny access to the user. Otherwise, users are granted access to the premise and the LCD display will print out the body temperature for monitoring.

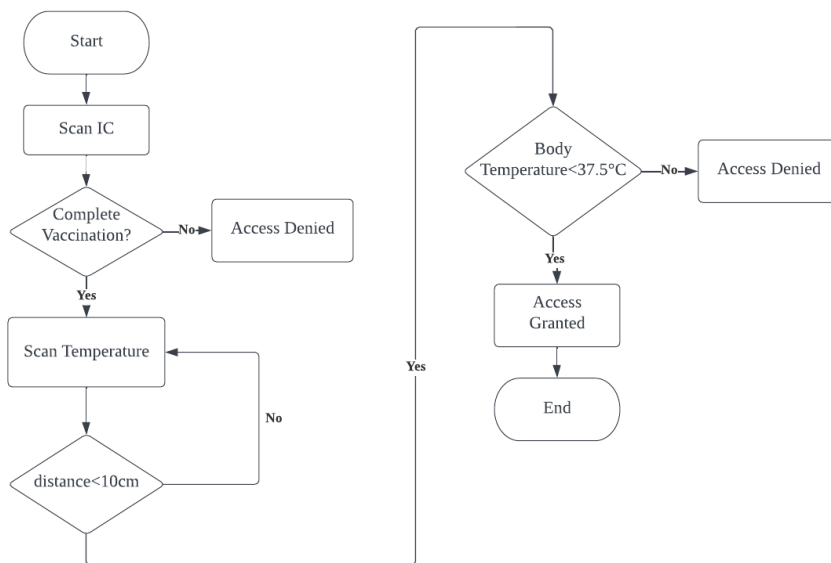

Figure 3 Overview of system workflow from user's perspective

Figure 4 shows the overall low level flow chart of the device. The NodeMCU ESP-12E will continuously check the WiFi connection and send signals to Arduino Uno through the implementation of USART. Once the circuit is connected

to WiFi, the RFID tag can now be scanned and read, the system will cross check with the local database containing users' details such as card UID, name and vaccination status to check whether the scanned tag is in the system, at the same time, the data associated with the RFID tag will be logged into another database associated with the premise named "Log". If the card owner is a registered user, it will proceed to check the vaccination status of the card owner. Card owner with complete vaccination will be granted access to the premise after their body temperature is read. Otherwise, access will be denied to those with incomplete vaccination or high body temperature.

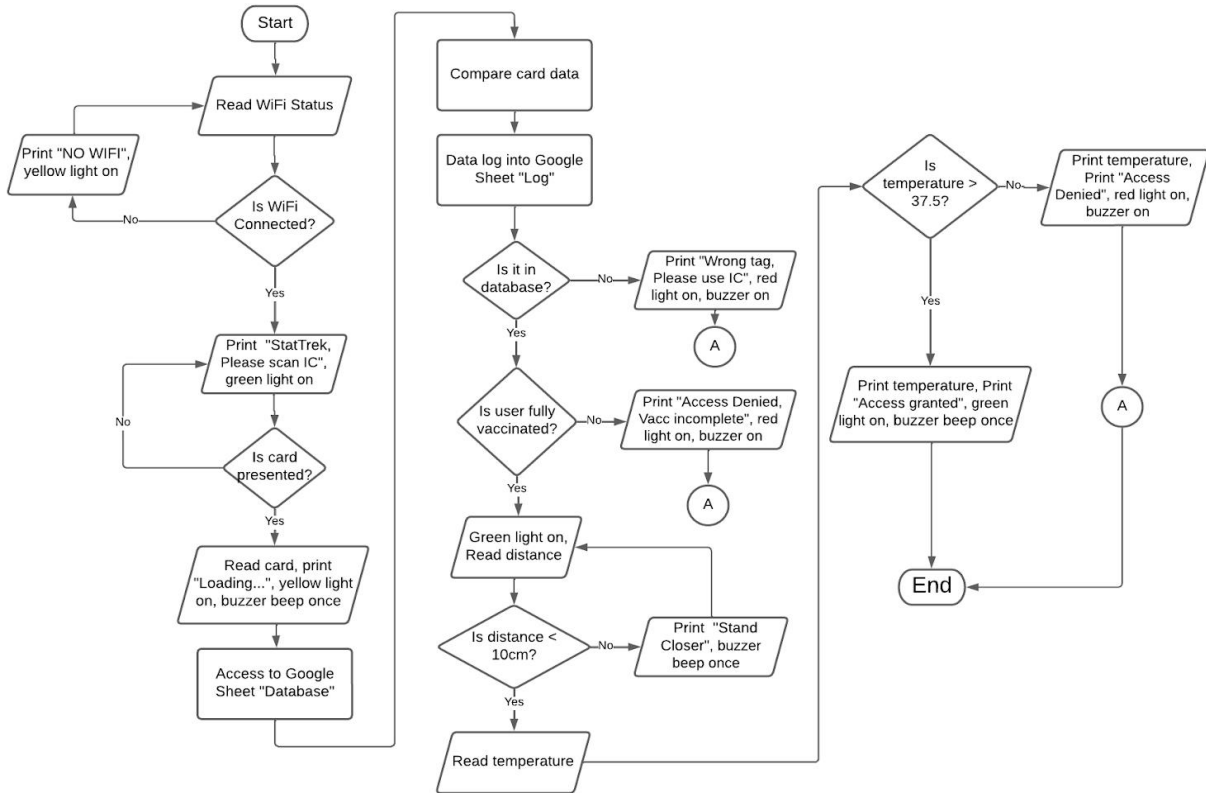

Figure 4 Detail behavioural flowchart of RFID record tracker

Figure 5 shows the example of local database containing the basic information of registered user such as their UID, name and vaccination status. It is the database in which the scanned tag will be crosschecked to confirm if the user fulfills the basic requirements to enter a premise. The local database is assumed to contain all MySejahtera users' information. Figure 5 also shows the database in which the data will be logged into and kept once a RFID card is scanned. It serves as a record for who enters the premise at what time. Figure 6 shows the front view of the final prototype with its components listed out.

UID	Name	vaccination
8fe865e9	Lim Su Shen	Complete
b6c9d948	Chua Jin Xiu	Incomplete
f3935f19	Wong Shu Yi	Incomplete
51f8fb26	Fatin Ayuni	Complete
aff8f2e9	Rowin	Complete
f62df3c	Hui Yeen	Complete
6888c32	Suraya	Complete
962f7432	Nurin	Complete
a6648b32	Wong Shu Yee	Complete
c6a78c32	Soh Xiao Wei	Complete
71773327	Nabihah	Complete
5ca123af	Dr Hau	Complete
169c8c32	Rita Rudaini	Incomplete

Date	Card UID	Name	Vaccination Status	Location
30/06/2022 12:59:38	51f8fb26	Fatin Ayuni	Complete	UTM
30/06/2022 14:06:09	c6a78c32	Soh Xiao Wei	Complete	biochiplab
30/06/2022 14:06:53	51f8fb26	Fatin Ayuni	Complete	biochiplab
30/06/2022 14:07:16	a6648b32	Wong Shu Yee	Complete	biochiplab
30/06/2022 14:10:25	f3935f19	Wong Shu Yi	Incomplete	biochiplab
30/06/2022 14:11:01	f3935f19	Wong Shu Yi	Incomplete	biochiplab
30/06/2022 14:15:18	8fe865e9	Lim Su Shen	Complete	biochiplab
30/06/2022 14:16:15	8fe865e9	Lim Su Shen	Complete	biochiplab
30/06/2022 14:16:53	962f7432	Nurin	Incomplete	biochiplab
30/06/2022 14:17:21	c6a78c32	Soh Xiao Wei	Complete	biochiplab
30/06/2022 14:18:28	5ca123af	ANONYMOUS		biochiplab
30/06/2022 14:19:50	5ca123af	Dr Hau	Complete	biochiplab
30/06/2022 14:20:15	5ca123af	Dr Hau	Complete	biochiplab
30/06/2022 14:20:59	5ca123af	Dr Hau	Complete	biochiplab
30/06/2022 14:21:24	5ca123af	Dr Hau	Complete	biochiplab
30/06/2022 14:26:42	c6a78c32	Soh Xiao Wei	Complete	biochiplab
30/06/2022 14:26:50	a6648b32	Wong Shu Yee	Complete	biochiplab

Figure 5 Example of local database: Database where data were logged once RFID tag was scanned

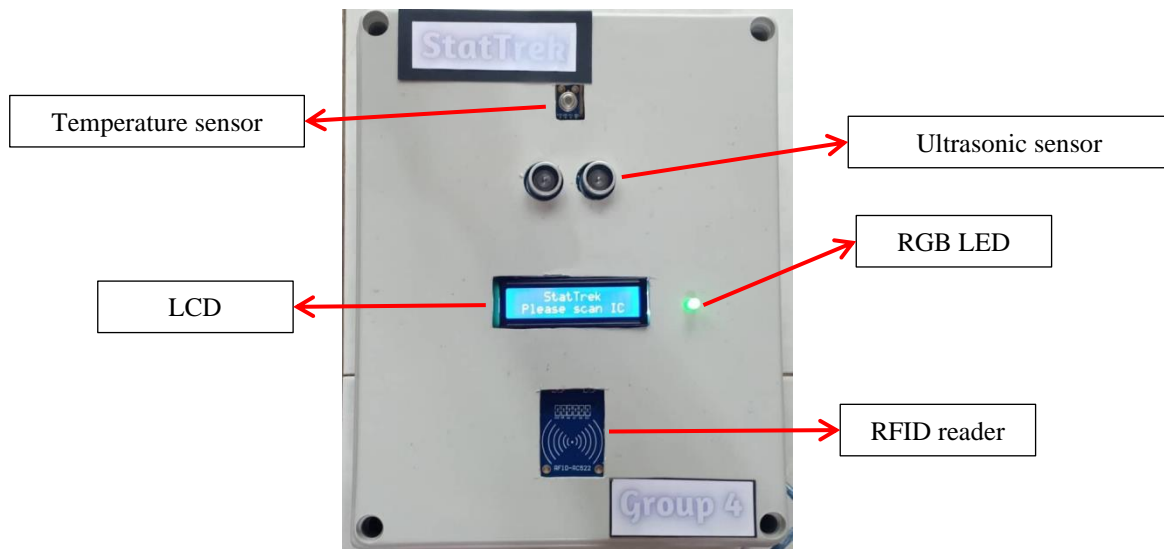

Figure 6 Final prototype of the RFID record tracker

3. Results and Discussion

3.1 Functionality verification

The LCD display is programmed to show users’ access to the premises, body temperature as well as WiFi connectivity of the proposed solution. The buzzer emits a certain tone in different instances. When the read body temperature is out of range or the user has incomplete vaccination status, it will sound more like a siren. If all parameters are met and the user is granted access to the premise, it will ring pleasantly. RGB LED is used to minimize the quantity of LED used in the prototype. It will be lit up in the color green when the user meets all the requirements, yellow during processing time and red if the user does not have access to the premise. The attached figures illustrate the functions of the proposed device when it was tested.

Figure 7(a) shows the device without WiFi connection, RGB LED will generate yellow colour indicating that the system is waiting for WiFi connection whereas Figure 7(b) shows the proposed device with WiFi connection which means it is ready to operate. Once an RFID card is scanned, the data associated with the card will be crosschecked with the local database. Figure 8(a) is the output if the vaccination status of the card owner is incomplete whereas Figure 8(b) is the output if the card is not registered in the database. For both circumstances, access to the premise will be denied and buzzer will produce siren sound to alert the premise owner. On the other hand, if the card owner is a registered user with complete vaccination, he or she can proceed to check their temperature. If their body temperature is within normal range, they are allowed to enter the premise as shown in Figure 9(a), else access denied as shown in Figure 9(b) and buzzer will be activated to alert the premise owner.

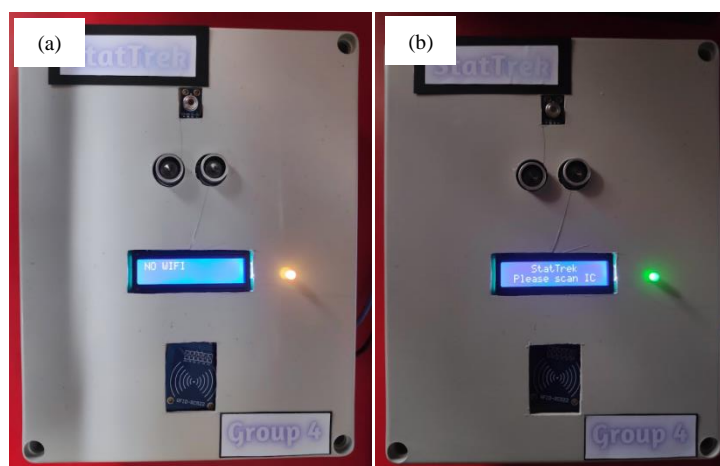

Figure 7 The device (a) without WiFi connection and (b) WiFi connection and ready to operate

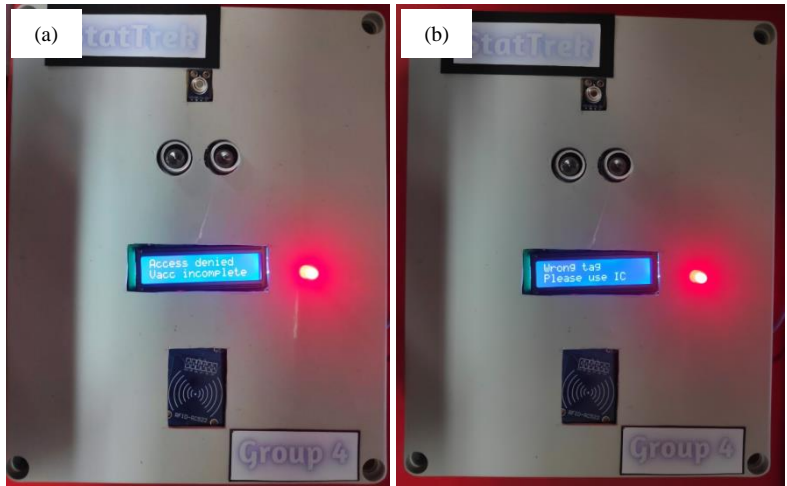

Figure 8 (a) Output display when vaccination status is incomplete and (b) output display when tag scanned is not found in the database

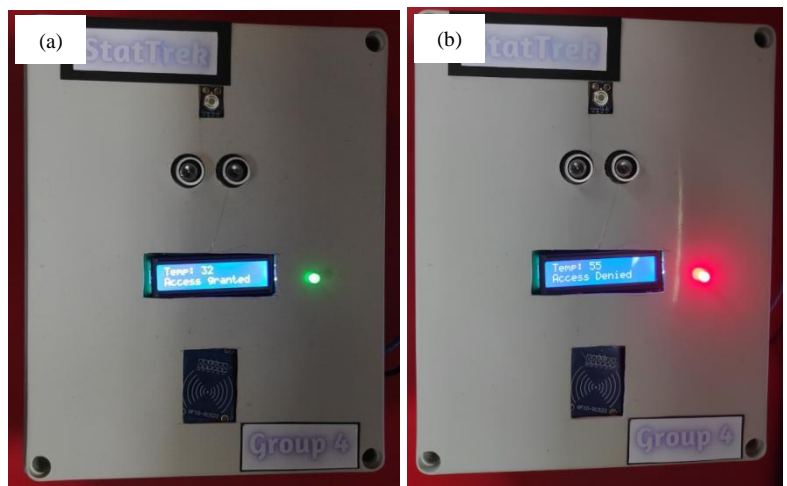

Figure 9 (a) Output display when temperature is within the set range and output display when temperature is out of the set range

3.2 Performance analysis

Table 1 shows the functionality validation of the proposed RFID record tracker based on electrical and mechanical parts. The electrical part included the programming test, ESP-12E NodeMCU, RFID tags and RFID reader, local database, HC-SR04 ultrasonic sensor, MLX90614 IR temperature sensor, LCD display, RGB LED and buzzer.

Table 1. Functionality validation

Performance Test	Result	Status
Programming test	Arduino Uno can be connected successfully to the other peripherals. It could upload and run the programming codes along with producing the output accordingly. No error detected in the code.	PASSED
ESP-12E NodeMCU test	Successfully applied USART interface to connect NodeMCU and Arduino Uno	PASSED Remarks: WiFi connection is needed in order for this proposed solution to operate as to access database in Google Script.
	Able to check WiFi status	PASSED

	Able to connect with serial devices	PASSED
RFID tags and RFID reader test	RFID reader can activate the RFID tags to retrieve data such as the EPC, users’ name, vaccination status and timestamp.	PASSED Remarks: <ul style="list-style-type: none"> ● A slow delay during the scanning process. ● Random tag will be read when multiple tags are scanned.
Local database test	The system can crosscheck with the local database and retrieve the information in the RFID tags. The system can log the data into the other database called ‘log’.	PASSED Remarks: <ul style="list-style-type: none"> ● Manual data entry is needed for initialization in the local database for new tags. ● Rebooting is needed to include new tag.
HC-SR04 ultrasonic sensor test	Ultrasonic sensor able to detect and read the distance of the proposed solution with a user.	PASSED
MLX90614 IR temperature sensor test	MLX90614 sensor can read temperature of the user.	PASSED Remarks: <ul style="list-style-type: none"> ● Sensor is very sensitive. ● Accuracy decreases when long distance.
LCD display test	Able to display the status of the user from the tags, distance, and temperature.	PASSED
RGB LED test	Able to light up according to different status: <ul style="list-style-type: none"> ● Yellow: No WiFi connection, loading time. ● Red: Wrong tag, incomplete vaccination, high temperature. ● Green: WiFi connected, fully vaccinated, temperature within range. 	PASSED
Buzzer test	Able to sound a certain way depending on the situations.	PASSED

4. Conclusion

The proposed RFID record tracker is a record tracking system that utilizes RFID technology to read user’s movements and previously visited locations. It also doubles as an attendance system, highly befitting schools and corporate businesses settings. This solution reads the embedded RFID chips available in an assortment of cards, such as Malaysian IC, student identification cards and staff cards.

This will not only minimize touch contacts, but it will also ease the process of checking in at locations as compared to scanning QR codes. The previous check-in process in Malaysia includes scanning a QR code and body temperature separately. Conversely, these steps could be done simultaneously with the proposed device without additional devices.

RFID technology is also proven to be dynamic, in which it provides real-time updates and can be overwritten. The efficiency and convenience of the proposed solution is also beneficial as it cuts off the processing time significantly due to its fast readability. The RFID chip also stores user’s information such as name and vaccination status in the database. However, an initialization process is needed to add new data to the said database.

All in all, this proposed RFID record tracker serves as an alternative to the 'Check-in' feature of MySejahtera, specifically aiming to cater to citizens who may not be familiar with technology or do not possess a smartphone. This need arises during the movement control order (MCO) period, a time when measures like contact tracing become essential to contain the spread of a highly contagious disease, such as the COVID-19 pandemic. The key benefits of this proposed solution include its simplicity, accessibility and inclusivity as no special device is required. The citizens only have to bring their identity card along with them wherever they go whereas the RFID reader is provided by premise owners or the Government.

Acknowledgment

The authors want to express their gratitude to Universiti Teknologi Malaysia for providing all necessary materials for the project.

Conflict of Interest

The authors declare no conflict of interest.

References

- [1] Ministry of Health & Department of Statistics Malaysia. (n.d.). Covid-19. KKMNOW. 2023. <https://data.moh.gov.my/covid> (accessed August 04. 2023).
- [2] H. J. Ho, Z. X. Zhang, Z. Huang, A. H. Aung, W. Y. Lim and A. Chow, Use of a real-time locating system for contact tracing of health care workers during the COVID-19 pandemic at an infectious disease center in Singapore: Validation study. *Journal of Medical Internet Research*, 2020, 22(5):e19437. <https://doi.org/10.2196/19437>.
- [3] S. J. S. Rajasekar, An enhanced IoT based tracing and tracking model for COVID-19 cases, *SN Computer Science*, 2021, 2(1):1–4. <https://doi.org/10.1007/s42979-020-00400-y>.
- [4] X. Jiang and A. E. Mohamed, The insufficiency of the Malaysian contact tracing app from the perspective of Chinese tourists: preparing for international tourism in the post-COVID-19 world, *Heliyon*, 2022, 8(12):e12154. <https://doi.org/10.1016/j.heliyon.2022.e12154>.
- [5] B. Yeo, Alternative to MySejahtera app needed for those with no smartphones says MP. *Focus Malaysia*. 2021. <https://focusmalaysia.my/alternative-to-mysejahtera-app-needed-for-those-with-no-smartphones-says-mp/> (accessed August 04. 2023).
- [6] O. G. Chiagozie and O. G. Nwaji, Radio frequency identification (RFID) based attendance system with automatic door unit, *Academic Research International*, 2012, 2(2):168.
- [7] M. R. Rieback, P. N. D. Simpson, B. Crispo and A. S. Tanenbaum, RFID malware: Design principles and examples, *Pervasive and Mobile Computing*, 2006, 2:405–426. <https://doi.org/10.1016/j.pmcj.2006.07.008>.
- [8] F. Chetouane, An overview on RFID technology instruction and application. *IFAC-PapersOnLine*, 2015, 48(3):382–387. <https://doi.org/10.1016/j.ifacol.2015.06.111>.