



A Customer Control Assistive Device Based on Microcontroller-based Embedded System for COVID-19 Pandemic

Joyce Xin Yee Lim^{1,*}, Nursyameera Athirah Aziz¹, Nur Farra Aisyah Nafriam¹, Yvonne Liang Liang Wong¹, Asem Ubaidur Rahman¹, Yuan Wen Hau^{1,2}

¹Department of Biomedical Engineering and Health Sciences, Faculty of Electrical Engineering, Universiti Teknologi Malaysia, 81310 UTM Johor Bahru, Malaysia.

²IJN-UTM Cardiovascular Engineering Centre, Institute of Human Centered Engineering, Universiti Teknologi Malaysia, 81310 UTM Johor Bahru, Malaysia.

* Corresponding Author limxinjoyce@graduate.utm.my

Received 29 June 2023; Accepted 05 August 2023; Available online 06 August 2023
<https://doi.org/10.11113/humentech.v2n2.59>

Abstract:

The study discusses the impact of COVID-19 in our daily lives and how social distancing is an effective method to prevent the spread of the virus. The paper highlights the importance of maintaining social distancing in crowded areas such as retail shops, which are at high risk of COVID-19 spread. To ensure social distancing, retail shops usually hire an employee to limit the number of customers in the shop. However, hiring a human employee during the pandemic comes with many disadvantages as the employee is at high risk of getting infected with the virus. To address this issue, the study developed a customer control assistive device based on automatic voltage regulator (AVR) microcontroller-based embedded system designed to help detect the number of people entering a particular area while minimizing the use of manual assistance. This device consisted of infrared sensors to detect the head count who enter or exit from a premises, as well as auto hand sanitizer system based on sensor and micro servo motor before a visitor enters the premises. With this assistive device, retailers now can set the total number of customers allowed to enter their shop by simply key in the total number of customers allowed to enter. This feature helps retailers to ensure that the number of customers is always within safe ranges automatically to maintain social distancing.

Keywords: AVR microcontroller; COVID-19; Customer limiting assistant; Infrared sensor; Micro servo motor; Social distancing.

1. Introduction

COVID-19 has rapidly affected our day-to-day life, businesses, disrupted world trade and movements. Governments and countries have established laws and regulations to control the spread of this virus. One of the most important methods to prevent the spread of this virus is maintaining social distancing by reducing the number of people in a certain area. Social distancing acts as a barrier between the person who might carry the virus and the other people. Social distancing has shown efficient results in reducing the spread of the virus among people, especially in crowded areas. Additionally, the estimated national social distancing policies in 46 countries prevented more than 1.5 million cases of COVID-19 in a two-week period, which projected a 65% reduction in new cases [1].

One of the places that are known for its crowds and people gatherings are retail shops, these places found to be areas with high risk of COVID-19 spread. To maintain social distancing, retail shops hire an employee to prevent overcrowding and to allow a safe experience for customers. However, hiring a human employee during COVID-19 spread comes along with many disadvantages, as the employee is going to be at high risk of getting infected with the virus. Moreover, it would increase the costs of the companies as they will have to pay for these employees. Finally, assigning an employee has a higher potential for human error to occur.

On 16th August 2021, Malaysian government along with Ministry of Health (MOH), Malaysia allowed retailer's shops to reopen while adhering to standard SOPs protocols. One of the standard operating protocols (SOPs) state that retail shops must only allow a certain number of customers to enter the store at the time, it is also advised for the customers to sanitize their hand before and after visiting the store [2]. In order to solve this problem, one of the easiest ways for most of the retailers to solve this problem is to hire workers at shop doors for manual calculation. However, this would bring more disadvantages such as the cost and the workload will increase. It will also increase the risk of COVID-19 spread. Minimizing the workload of the staff is one of our aims to overcome this problem as most of the staff tend to worry excessively in the workforce due to COVID-19 that can affect their job performance [3].

As a solution to fulfil these requirements, a device to organize the flow of customers entering or exiting a certain place was developed in this study. Additionally, this device offers a touchless sensor-based sanitizing system attached to it. This study will help many companies to ensure safe and legal return after this pandemic, it will also help companies to get the advantage of using the new technologies of automated systems to ensure accurate workflow and reduce costs and expected errors which help to solve the understaffed issues. This study is divided into two categories which are targeted technology and targeted market. For targeted technology, this study mainly includes different kinds of parameters for both output and input parameters. The updated outputs included light emitting diodes (LEDS), liquid crystal display (LCD), micro servo motor SG-90 and piezo buzzer. that contributed to the system workflow. Meanwhile, for the input parameter, 4×4 matrix keypad, push button and infrared (IR) sensor to detect the presence of the customer were used, so that the current status of the counted number of customers will be updated. The system was controlled by Arduino MEGA 2560 (ATmega 2560) which consisted of 54 digital input/output pins, which is more than the number of pins in Arduino UNO. It also provides 256 KB of flash memory to send the data to other output parameters.

2. Methodology

2.1 Project design

The methodology includes the description on the top-level architecture, system workflow, instrument for input parameters, software algorithm and final prototype.

2.1.1 Top level functional block diagram / System architecture

The system architecture was further shown as a top-level architecture in the form of a block diagram, as shown in Figure 1. Two IR sensors, one push button, and one 4×4 matrix keypad membrane were categorized as input channels of the design project, while LEDs, a piezo buzzer, a 16×2 LCD display, and a micro servo motor were categorized as output channels. For the input channels, a 4×4 matrix keypad was used to allow the users to enter the maximum number of customers allowed inside the shop. Infrared sensors were placed at both entrances and exits to detect the presence of customers. Moreover, the push button was designed to reset the system when errors occurred.

The microcontroller used was Arduino MEGA 2560, processed by ATmega 2560, which controlled and processed signals received from all input channels accordingly. For the output channel, the 16×2 LCD display displayed the necessary information such as the maximum and current number of customers. Next, micro servo motors and IR sensors were incorporated together to indicate the presence of customers. For example, if IR sensors detected a customer, the micro servo motors would rotate to function as a spray hand sanitizer pump for hand sanitizing purposes.

Meanwhile, LEDs were switched on according to different situations based on the maximum number of customers set by the users. Green LEDs indicated "ENTER," where customers had sanitized their hands successfully and could enter the shop. Next, the red LEDs indicated "QUEUE," which showed that the maximum number of customers had been reached, and customers needed to queue up patiently at the waiting area. Furthermore, yellow LEDs indicated "READY," which showed that the current number of customers was less than the maximum number of customers, and customers should be ready to walk towards the entrance for hand sanitizing purposes.

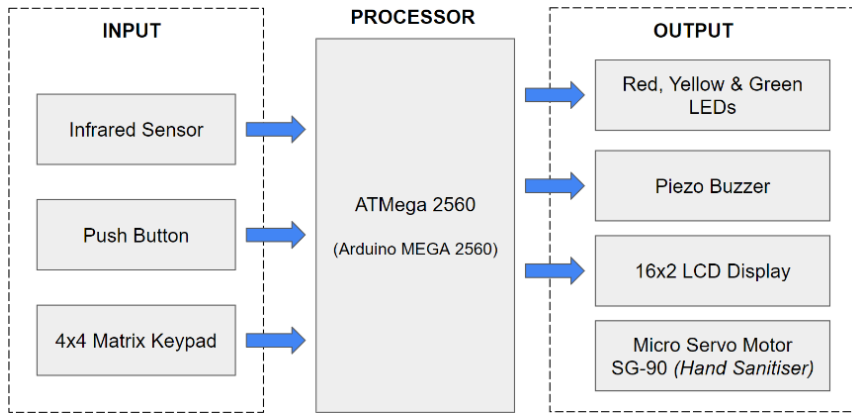

Figure 1 System architecture of overall project

In addition, the piezo buzzer produced sound to alert the users as errors occurred. For example, if the maximum number of customers had been reached but there were still customers entering the shop, the red LEDs lit up, and the piezo buzzer produced sound to notify that the system needed to be adjusted. The users reset the system again by pressing the push button and keying in the current number of customers to allow the whole system to start counting based on the current number of customers. The piezo buzzer only stopped producing sound when the users pressed the push button.

Figure 2 shows the overall schematic diagram using Proteus software. Infrared sensors, a 4×4 matrix keypad, a 16×2 I2C LCD display, yellow, green, and red LEDs, servo motors, a piezo buzzer, and a push button were connected to the Arduino ATmega 2560 board, respectively.

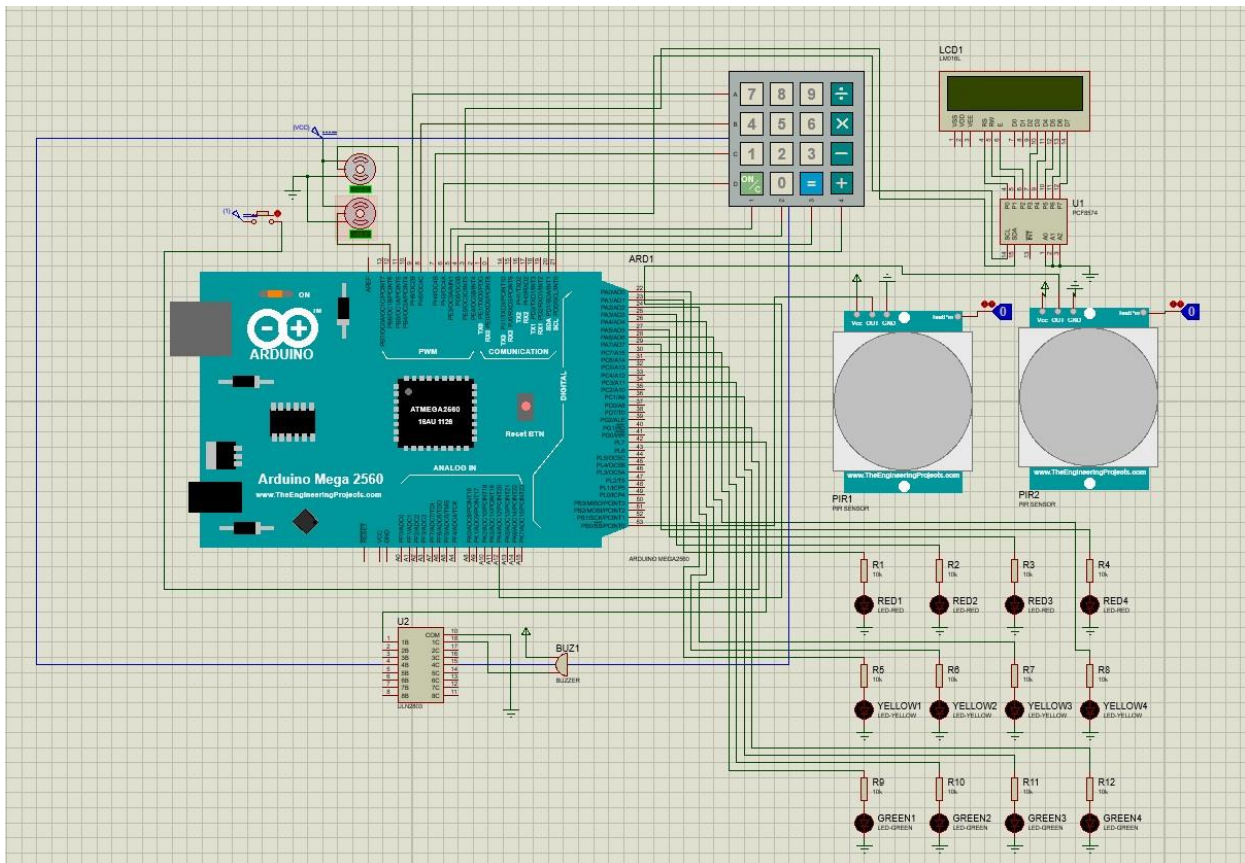

Figure 2 Overall schematic diagram

The device played a main role in detecting the number of customers in both entrance and exit to ensure the amount of customers inside the enclosed space was below the maximum limit. Initially, the user needed to key in the maximum number of customers allowed to enter the enclosed space, which was displayed on the 16×2 LCD display. Then, the 16×2 LCD display showed the current number of customers starting from zero.

From the perspective of customers, they needed to queue at the waiting area first. The LEDs lit up according to the situations and were further explained in a low-level flowchart. For example, yellow LEDs lit up to indicate "READY" mode, where customers at the waiting area could be ready to walk towards the entrance for hand sanitizing purposes and entry. Furthermore, green LEDs lit up to indicate "ENTER" mode, where customers could enter the shop and have sanitized their hands successfully. Then, red LEDs lit up to show "QUEUE" mode, indicating that customers needed to queue up patiently at the waiting area as the maximum number of customers had been reached. Both hand sanitizers at the entrance and exit were generated by Micro Servo Motor SG-90.

In this device, the analog sensor used was IR sensors, as shown in Figure 3. It was able to detect motion or the presence of an object by employing an IR sensor, which emitted IR lights to sense some aspect of the surroundings [4]. Furthermore, it could only measure IR radiation since it was a passive sensor. The IR sensor had 3 pins that could connect with the external environment, as shown in Figure 3. It was small in size and had low power consumption. It offered high flexibility with various device operation options. This sensor was the best choice with its low-cost, high-precision sensing solution for detecting human presence by measuring a range from 20 to 150 cm. Therefore, whenever a customer entered or left the venue, IR sensors were able to accurately detect their presence.

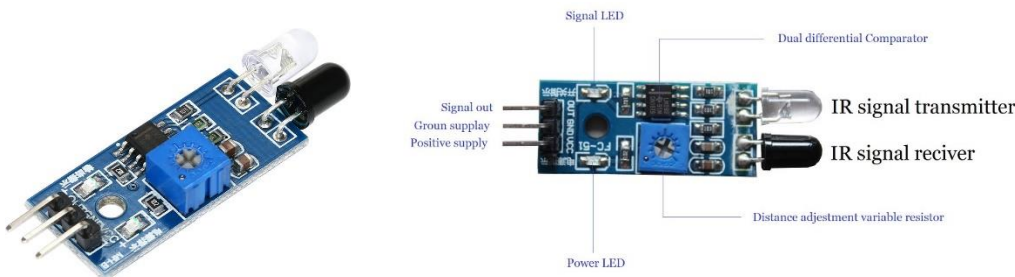

Figure 3. Pins layout of IR sensor

Figure 4 shows the analogue circuit design of IR sensors. Infrared LED acted as the transmitter, while the photodiode acted as the receiver. When a customer stood in front of the sensor, the photodiode automatically detected the reflected light from the customers. Furthermore, an LM358 operational amplifier was also connected to perform the comparison and generate output. Moreover, a potentiometer was included in the IR sensor to allow users to adjust the sensitivity and triggering distance accordingly.

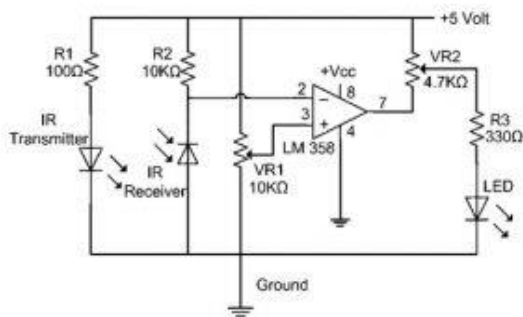

Figure 4. Circuit diagram of IR sensor

2.2 System workflow

Figure 5 below shows the system workflow of the device. The device plays a main role in detecting the number of customers in both entrance and exit to ensure the amount of customers inside the enclosed space is below the maximum

limit. First, the user needs to key in the maximum number of customers allowed to enter the enclosed space and displayed on the 16×2 LCD display. Then, the 16×2 LCD display will show the current number of customers starting from zero.

From the perspective of customers, they will need to queue at the waiting area first. The LEDs will light up according to the situation and will be further explained in low-level flowchart. For example, yellow LEDs light up to indicate “READY” mode where customers at the waiting area can be ready to walk towards the entrance for hand sanitizing purposes and entry. Furthermore, green LEDs light up which indicate “ENTER” mode where the customers can enter the shop and have sanitised their hand successfully. Then, red LEDs light up to show “QUEUE” mode which indicates that the customers need to queue up patiently at the waiting area as the maximum number of customers has been reached. Both hand sanitiser at entrance and exit will be generated by Micro Servo Motor SG-90. Figure 6 explains the detailed flow of the device by showing in the form of the low-level flow chart.

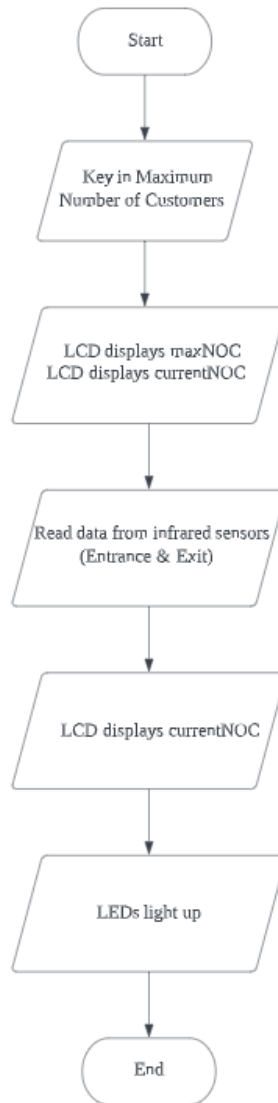

Figure 5. High-level flowchart of overall project

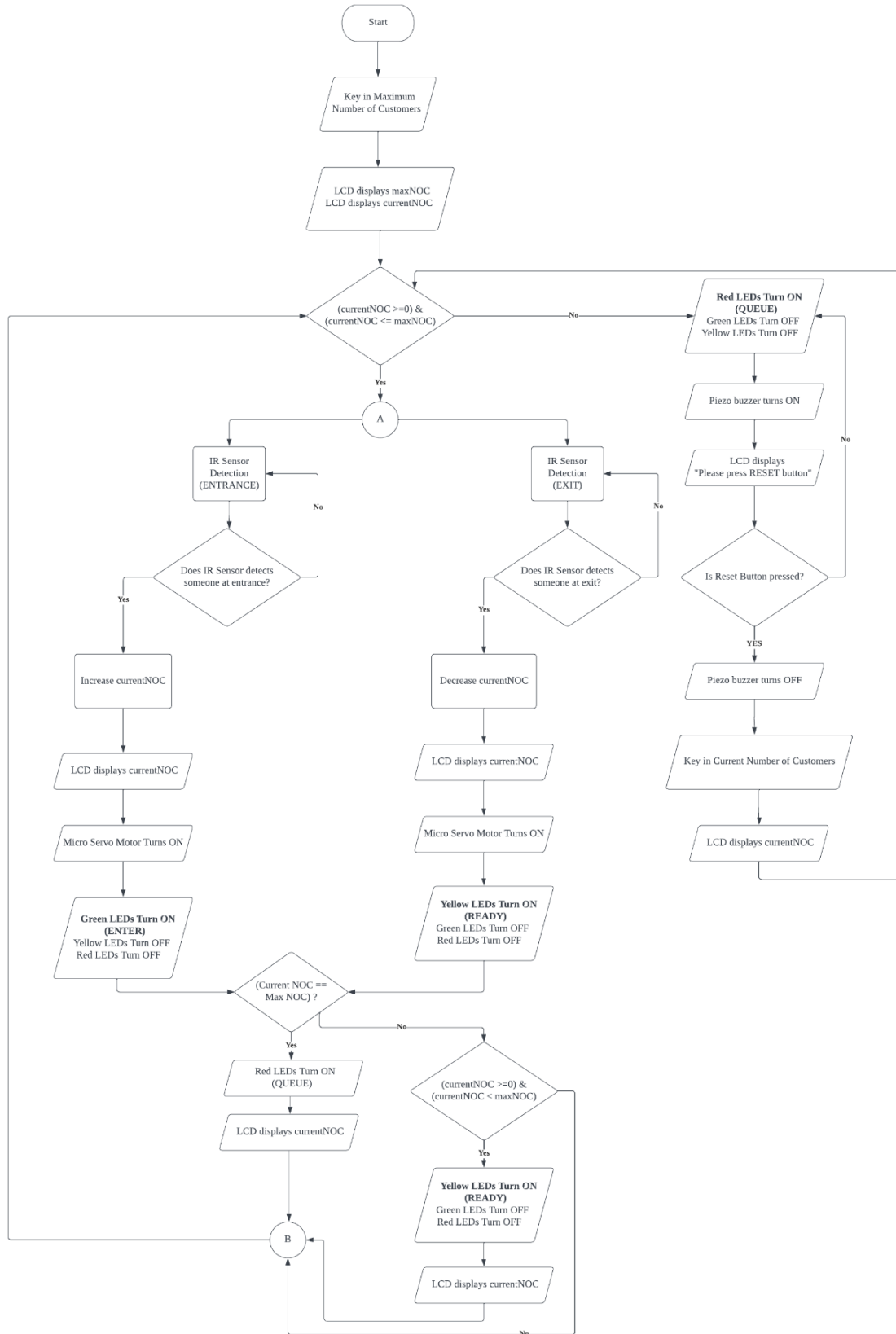

Figure 6. Low-level flowchart of overall project

© 2023 Penerbit UTM Press. All rights reserved

3. Results and Discussion

3.1 Functionality and verification

The final prototype was divided into two parts which are mechanical and technical parts. For the technical part, the overall system was controlled by Arduino MEGA 2560 that provides 54 digital input/output pins. The output components are LEDs, LCD display, micro servo motor SG-90 and piezo buzzer. In this project, 4 LEDs were used in each color (RED, GREEN and YELLOW) and all LEDs light up according to the instructions. The same goes to the LCD display and piezo buzzer. As for micro servo motor SG-90, it takes some time to enable the servo motor to spray the hand sanitizer but some adjustment and improvement on technical and mechanical parts has successfully made the servo motor to function well as shown in Figure 7. Meanwhile, for the input parameter, we have used the 4×4 matrix keypad, Push button and IR sensor which plays a major role in the final prototype of the overall system. These two components also managed to function well as they were operated according to the coding instruction.

The functionality and verification of the mechanical part are also considered as there were some major improvements that have been made from the limitations that have surfaced while building up the final prototype as shown in Figure 8. The contribution of the bottle of the hand sanitizer also plays a major role in achieving our project objectives. The first trial of making the bottle to spray the hand sanitizer failed due to the strength of the servo motor which affected the bottle to spray. Eventually, the bottle was able to spray successfully by placing wires from the handle of the spray bottle to the servo motor. The overall prototype diagram was depicted as shown in Figure 9.

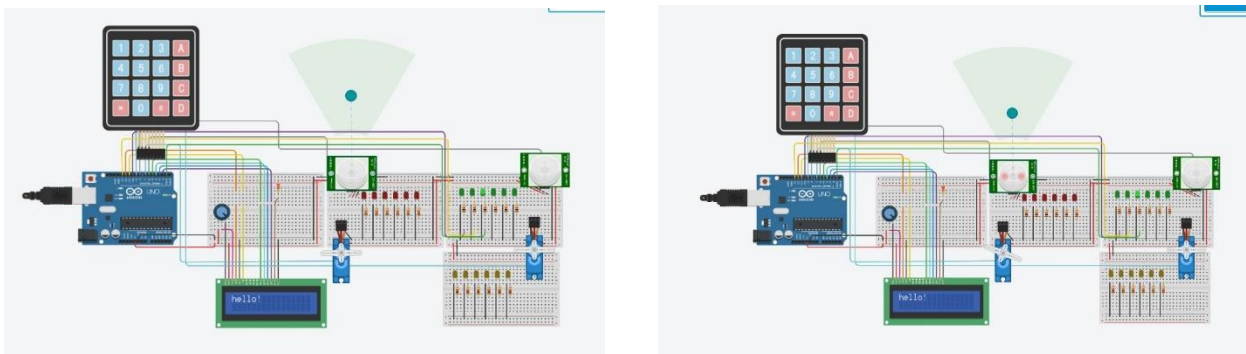

Figure 7. Micro servo motor remain static when no motion was detected by the IR sensor (left) and micro servo motor rotates 180° when motion was detected approximately 3 cm (right)

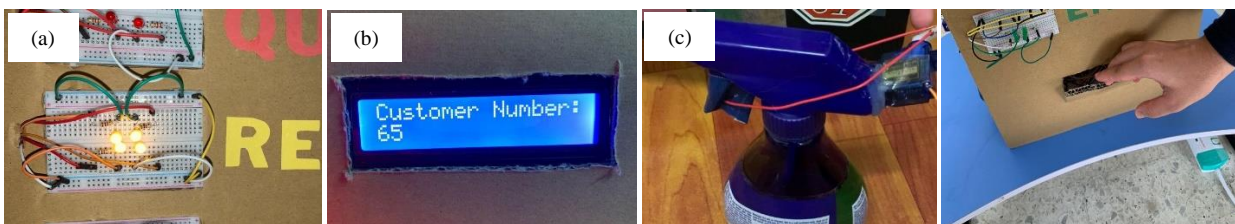

Figure 8. Functionalities of (a) LEDs, (b) LCD display and (c) mechanical part

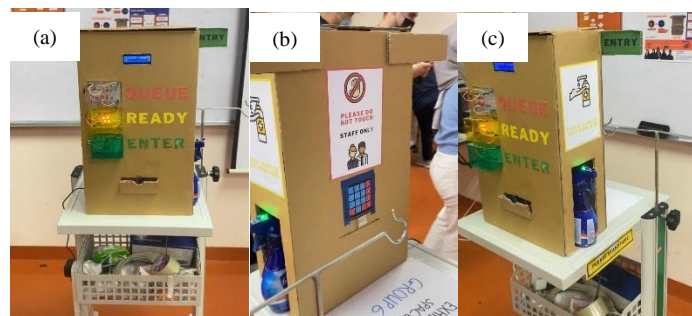

Figure 9. Overall device system: (a) Front view, (b) back view and (c) isometric view

3.2 Performance analysis

Table 1 shows the performance analysis of the device based on electrical and mechanical parts. The electrical part included the programming test, IR sensor, 12 output LEDs and micro servo motor SG-90.

Table 1. List of electronic and mechanical components

Part	Performance test	Performance
Electrical	Programming test	The Arduino MEGA 2560 was able to connect successfully with other hardware of the circuit. It can be shown as all of the components operated according to the coding instruction and no error detected in the code after the debugging process has been made.
	IR sensor	The IR Sensor was placed at the top of the bottle of the hand sanitizer and it was able to detect the presence of the customer in the range of approximately 3-25 cm while preventing any unwanted particle movement from being detected.
	12 output LEDs -GREEN LEDs -YELLOW LEDs -RED LEDs	The 12 LEDs were able to light up to indicate the status of the customer entry and exit from the shop.
	Micro servo Motor SG-90	The Micro Servo Motor SG-90 managed to spray the hand sanitizer bottle when the IR Sensor detected the presence of the customer.
	Piezo buzzer	The piezo buzzer has successfully managed to produce sound when the number of customers reaches its maximum value of the customer.
	4×4 matrix keypad	The desired number of customers was able to key in from the 4×4 matrix keypad and it will then display in the LCD display.
	LCD 1602 with I2C module	The LCD Display was able to display the current number of customers.
	Push button	When the push button was pressed by the staff, the piezo buzzer stop produced the tone indicating that the push button is working well.
	AC to DC power adapter (9V 1A)	The power adapter was able to provide power supply in order to turn on the overall system.
Mechanical	Hand sanitizer bottle	The hand sanitizer bottle was able to spray the hand sanitizer towards the customer in order to prevent spread of COVID-19.

3.3 System validation

Quantitative analysis for sensor detection entails measuring and examining sensor data to extract meaningful information and make objective assessments. The effectiveness, sensitivity, specificity, and overall performance of a sensor in detecting targets or events are frequently assessed using this methodology [5]. A total of 10 subjects were used as samples in determining the accuracy and precision of IR sensor modules with different speeds. Table 2 shows the results of the assessment.

Table 2. Different speeds validation results

No.	Distance (m)	Time (s)	Speed (km/h)	Walking speed	Results	Observations
1	2	5.25	1.37	Slow paced walking	Able to detect	Both enter and exit sensor were able to detect the presence of subjects by emitting lights
2	2	5.12	1.41	Slow paced walking	Able to detect	Both enter and exit sensor were able to detect the presence of subjects by emitting lights
3	2	5.1	1.41	Slow paced walking	Able to detect	Both enter and exit sensor were able to detect the presence of subjects by emitting lights
4	2	4.82	1.49	Slow paced walking	Able to detect	Both enter and exit sensor were able to detect the presence of subjects by emitting lights
5	2	4.46	1.61	Normal paced walking	Able to detect	Both enter and exit sensor were able to detect the presence of subjects by emitting lights
6	2	4.35	1.66	Normal paced walking	Able to detect	Both enter and exit sensor were able to detect the presence of subjects by emitting lights
7	2	3.81	1.89	Normal paced walking	Able to detect	Both enter and exit sensor were able to detect the presence of subjects by emitting lights
8	2	3.45	2.09	Normal paced walking	Able to detect	Both enter and exit sensor were able to detect the presence of subjects by emitting lights
9	2	2.85	2.53	Fast paced walking	Able to detect	Both enter and exit sensor were able to detect the presence of subjects by emitting lights
10	2	2.35	3.06	Fast paced walking	Able to detect	Both enter and exit sensor were able to detect the presence of subjects by emitting lights

4. Conclusion

Customer Limiting Assistant is a device that helps detect the number of people entering a particular area while minimizing the use of manual assistance. The basic concept of this device is to allow only a certain number of people to enter a room and offer a sanitizing system to ensure a low risk of COVID-19 spread. Embarking on product fabrication by choosing the right components and material to ensure the functionality verification runs well. The main components used to build the product are an IR sensor, micro servo motor SG-90, Arduino Mega 2560, LCD and 4x4 matrix membrane keypad. The programming software that we fully utilize is Arduino IDE.

This device comes with a great benefit explicitly offered to the retail industry. Starting from the retailer's perspective, to ensure the number of customers does not exceed the shop limit. With this device, retailers now can set the

total number of customers allowed to enter their shop by simply key in the total number of customers allowed to enter. This feature helps retailers to ensure that the number of customers is always within safe ranges automatically to maintain social distancing. Moreover, the device will bring advantages in cost savings and manpower. Since the device will automatically count the number of customers going in and out of the store, there will be no workforce needed to do the duty. This will automatically reduce the cost of hiring more staff. Furthermore, the device also helps add the product value of helping the community to ensure their low risk of COVID-19 infection, the device also offers a sanitizing system that is programmed to sanitize customers during entry and exit movement.

In addition, the device also brings benefits to the healthcare sector and the entire community. By fully utilizing the device, it can help people be more disciplined in following the standard operating procedures that are already implemented in enclosed areas. The main standard operating procedures applied on the device are clean hands using hand sanitizer before and after shopping and practising 1 m physical distancing. This will help in reducing the number of people infected by COVID-19.

Acknowledgment

The authors want to express their gratitude to Universiti Teknologi Malaysia for providing all necessary materials for the project. The authors want to thank everyone who worked on this study and provided feedback that helped them make it better.

Conflict of Interest

The authors declare no conflict of interest.

References

- [1] D. J. McGrail, J. Dai, K. M. McAndrews and R. Kalluri, Enacting national social distancing policies correspond with dramatic reduction in COVID19 infection rates. *PLoS ONE*, 2020, 15(7):e0236619. <https://doi.org/10.1371/journal.pone.0236619>.
- [2] A. Firdaus, Fasa 1 PPN: Kerajaan setuju buka 11 sektor ekonomi mulai 16 Ogos, *AstroAwani*, 2021. <https://www.astroawani.com/berita-malaysia/fasa-1-ppn-kerajaan-setuju-buka-11-sektor-ekonomi-mulai-16-ogor-314131> (accessed August 04. 2023)
- [3] E. Ingusci, F. Signore, M. L. Giancaspro, A. Manuti, O. Molino, V. Russo, M. Zito and C. G. Cortese, Workload, techno overload, and behavioral stress during COVID-19 emergency: the role of job crafting in remote workers. *Frontiers in Physiology*, 2021, 12:655148. <https://doi.org/10.3389/fpsyg.2021.655148>.
- [4] K. A. Muthukumar, M. Bouazizi and T. Ohtsuki, An infrared array sensor-based approach for activity detection, combining low-cost technology with advanced deep learning techniques, *Sensors*, 2022, 22(10): 3898. <https://doi.org/10.3390/s22103898>.
- [5] H. Mohamadipanah, B. Wise, A. Witt, C. Goll, S. Yang, C. Perumalla, K. Huemer, L. Kears and C. Pugh, Performance assessment using sensor technology, *Journal of Surgical Oncology*, 2021, 124(2):200–215. <https://doi.org/10.1002/jso.26519>.